

# AJAX<sup>®</sup> C-302 Separable 2-Throw Compressor

Engineered for Your Environment



The latest addition to the AJAX Green Team

The AJAX product team introduces the new environmentally friendly compressor, the C-302. It has the economical advantages of an AJAX slow speed compressor without the air quality permit issues related to an internal combustion engine.

Added to the AJAX line of slow speed reciprocating compressors is the C-302 separable. Benefits of the C-302 Include:

- **Slow speed** – Efficient, lower operating cost
- **Proven AJAX technology** – Reliable, tough, low maintenance
- **Electric motor driven** – No emissions, less noise
- **Balanced opposed crankshaft** – Smaller footprint and low vibration
- **Offered as a complete package or frame and cylinders only**

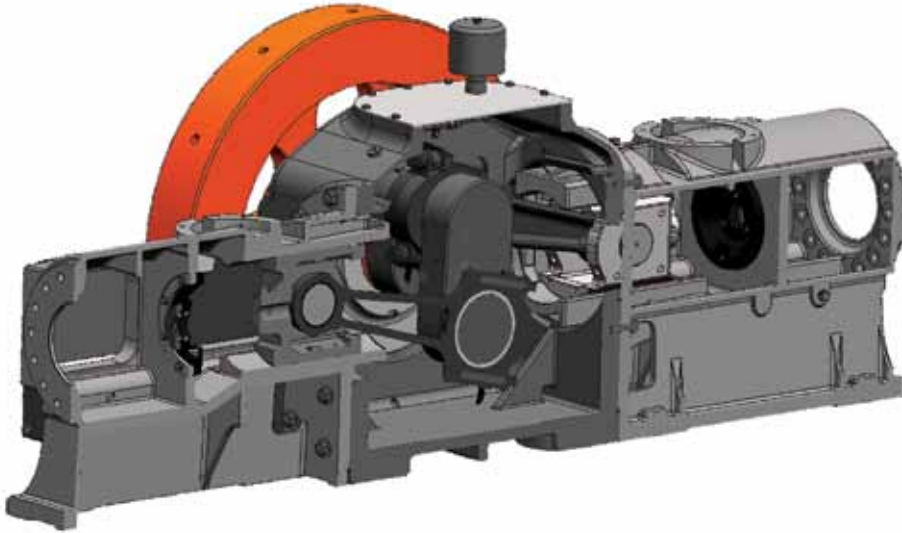

### C-302 Specifications

Approximate Package Dimensions	300" x 99 <sup>1</sup> / <sub>8</sub> " x 102" (LHW)
Weight	43,486 lbs
Rated Speed	455 RPM
Speed Range	STD 260-455 RPM (200-455 optional)
Throws	2
Stroke	11 in. (279 mm)
Rod Load Rating	30,000 lbs. (13,608 kg)
Piston Rod Diameter	2.5 in. (63.5 mm)
CHP Rating	Up to 300 CHP (223 kW)
Mean Piston Speed	834 fpm (254 m/min)
Balanced opposed crankshaft with throws offset by 180 crank degrees	

### Interchangeable Parts

Most parts on the C-302 are interchangeable with the rest of the AJAX integral engine compressor product line, including:

- 11" stroke compressor cylinders
- All unit consumables
- Rods
- Rod bearings

The C-302 only has four new parts – the frame, flywheel, crank shaft and drive hub.



Electric motor driven separable

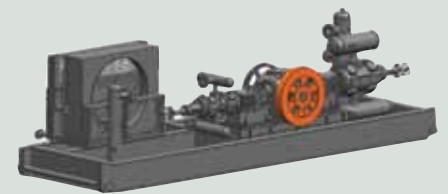

Side-mounted cooler available



Cameron strives for continuous improvement in all aspects of our business. Cameron reserves the right to modify designs and specifications without notice or obligation. Nothing contained in this brochure is intended to extend any type of warranty, expressed or implied.

Cameron  
2101 S.E. 18th Street  
Oklahoma City, OK 73129  
USA  
Tel 405.670.4121

[www.c-a-m.com/ajax](http://www.c-a-m.com/ajax)